



Memorandum

To: Stormwater Quality Standards Study Task Force

From: CDM

Date: June 30, 2006

Subject: Economic Analysis of Compliance Alternatives

This technical memorandum presents the results of a preliminary economic analysis of compliance alternatives for potential solutions to comply with existing bacteria water quality objectives at three study subwatersheds in the Santa Ana River Basin. The analysis includes:

- Development of a probabilistic water quality model
- Review of four potential bacteria treatment alternatives
- Estimation of costs of compliance for each of the three study subwatersheds

Introduction

Three study subwatersheds were selected to assess the cost of complying with water quality objectives for contact recreational use. The subwatersheds were selected by the Stormwater Quality Standards Study Task Force (Task Force) and include the Santa Ana Delhi Channel (Orange County), Temescal Wash (Riverside County), and Chino Creek (San Bernardino County) watersheds. This technical memorandum provides a site description and summary of existing bacteria and flow data for each of the subwatersheds.

This analysis is intended to support the consideration of economics in the context of California Water Code (CWC) Section 13241, which requires that economics be considered as a factor when establishing water quality objectives.

Water Quality Modeling

The preliminary economic analysis of compliance alternatives utilized a probabilistic water quality model to incorporate the uncertainty of bacteria conditions in large watersheds with varying sources from diverse land uses. Pathogen indicator bacteria concentration data collected from each subwatershed were extracted from a database of historical water quality measurements developed in Phase I of the Stormwater Quality Standards Study (SQSS). These data were used to develop a predictive model of potential in-stream bacteria

concentrations, taking into account relationships between bacteria and flow conditions (each of the subwatersheds contains a flow gauge at a representative downstream location). The model applies various treatment scenarios to a series of potential daily conditions over the course of one year and generates a probability density function (PDF) of downstream bacteria concentration. This PDF curve shows the likelihood of bacteria water quality objectives being exceeded. For two of the three watersheds, the predominant available data was fecal coliform, used in the current Basin Plan water quality objectives for recreational use. EPA proposed water quality objectives for *E. coli* were used at the one site where the predominant data was *E. coli*. The development of the model and its application for the three subwatersheds is discussed in this technical memorandum.

Compliance Method Evaluation

Structural best management practices (BMPs) for this preliminary economic analysis were selected that have been shown to be effective at reducing bacteria concentrations. Several options were analyzed for possible use in each of the subwatersheds, including:

- Constructed wetlands
- Infiltration basins
- Dry weather diversions to wastewater treatment plant(s)
- Conventional disinfection facilities

Each of these options is described in detail in Section 4 of this technical memorandum. The compliance options evaluated in this analysis are intended to treat the runoff from the study subwatersheds at a single location at a downstream point in the runoff capture area of the study subwatershed. For this analysis, compliance with water quality objectives in downstream receiving waterbodies assumed no regrowth of bacteria downstream of the structural BMP or within the receiving waterbody. While the selected locations were strategically located close to the confluence with a significant downstream receiving waterbody, the potential for bacteria regrowth is a concern.

The use of multiple more localized structural BMPs distributed throughout the watersheds, and the use of non-structural source control measures was not assessed as part of this preliminary analysis. The effectiveness of such measures is difficult to predict in large urbanized watersheds, but these approaches should be considered in future watershed plans.

The facility requirements necessary to achieve compliance with existing water quality objectives for fecal coliform were analyzed for several flow conditions, including runoff generated from both 0.1 inch and 0.5 inch rainfall events, as well as the runoff from a storm event that would result in a channel depth-velocity product of at least 10 ft²/sec (a condition that is specified as dangerous for USGS field personnel to wade in when collecting discharge

measurements). The analysis examined the aforementioned structural BMP alternatives that were feasible at each location under each flow condition. The selection of flow conditions and methods used to identify them for each subwatershed are described in this technical memorandum.

Economic Analysis

Planning level costs were developed for the structural BMP alternatives that might be feasible in each of the subwatersheds, assuming that that land can be acquired and assuming there are no insurmountable engineering or environmental constraints. Costs were developed by compiling quotes obtained from several different vendors, obtaining probable cost of construction estimates from other published sources including information developed for Task Force members, and construction estimates prepared by CDM Constructors Inc (CCI). Land acquisition cost was estimated by researching current properties for sale in the region of each subwatershed, and applying a unit cost per acre.

The costs are presented as a range and are only intended to provide the Task Force with a n order-of-magnitude estimate of the potential costs for complying with bacteria water quality objectives at each of the subwatersheds.

Study Subwatersheds

The following subsections briefly describe the study subwatersheds and available data.

Santa Ana Delhi Channel Subwatershed

The Santa Ana Delhi Channel subwatershed has an approximate drainage area of 20 mi² and is comprised of primarily urban areas in the Cities of Santa Ana, Irvine, Costa Mesa, and Newport Beach, which drain to Upper Newport Bay (Figure 1).

Water Quality data for the Santa Ana Delhi Channel were obtained and analyzed in Phase I of the Stormwater Quality Standard Study (SQSS). Recent (1990 to present) water quality samples from the Santa Ana Delhi Channel where it drains into Upper Newport Bay were collected and analyzed by the Orange County Health Care Agency. A total of 419 samples were collected between 1990 and 2005 on days with flow recorded at the Irvine Avenue crossing. Of the 419 samples, 383 were collected during dry weather and 36 during wet weather.

The Orange County Resource and Development Management Division (RDMD) provided flow at 30-minute intervals for the Santa Ana Delhi Channel at a gage located upstream of the Irvine Avenue bridge. Flow records were available for the period between 1992 and 2004. Available flow data from this flow gauge was processed to facilitate time series plotting and frequency distribution analysis. These data are incorporated into a water quality model used to estimate a mass balance and associated concentrations of bacteria upstream and downstream of different modeled structural treatment BMPs.



Figure 1
Map of the Santa Ana Delhi Channel Subwatershed

A potential structural treatment BMP location is at the downstream end of the Santa Ana Delhi Channel upstream of where it drains into Upper Newport Bay.

Temescal Wash Subwatershed

The Temescal Wash Subwatershed has an approximate drainage area of 224 mi² and consists of a diverse mixture of land uses including urban, agricultural, industrial and natural (Figure 2). This drainage area does not include the watersheds above Lake Matthews and Lake Elsinore. These lakes do not overflow into Temescal Wash during most years; however overflows following some very wet years can have a significant impact on flow conditions in Temescal Wash.

Water Quality data for Temescal Wash were obtained and analyzed in Phase I of the Stormwater Quality Standards Study (SQSS). Recent (2002 to 2005) water quality samples from Temescal Wash where it drains into the Prado Wetlands were collected and analyzed by the Orange County Coastkeeper. A total of 28 samples were collected between 2002 and 2005 and analyzed for E. coli on days with flow recorded at the Main Street crossing. Of the 28 samples, 25 were collected during dry weather and 3 during wet weather.

Flow in Temescal Wash is recorded by the USGS approximately 1 mile upstream of the Lincoln Avenue Bridge, where Temescal Wash passes under Main Street in Corona [USGS

Gage 11072100]. Available flow data from this flow gauge was processed to facilitate time series plotting and frequency distribution analysis. The collected flow data was recorded in 15 minute intervals for the period between 1988 and 2005. These data are incorporated into a water quality model used to estimate a mass balance of bacteria upstream and downstream of different modeled structural treatment BMPs.

A potential structural subwatershed treatment BMP location is at the downstream end of Temescal Wash upstream of where it drains into the Prado Wetlands.

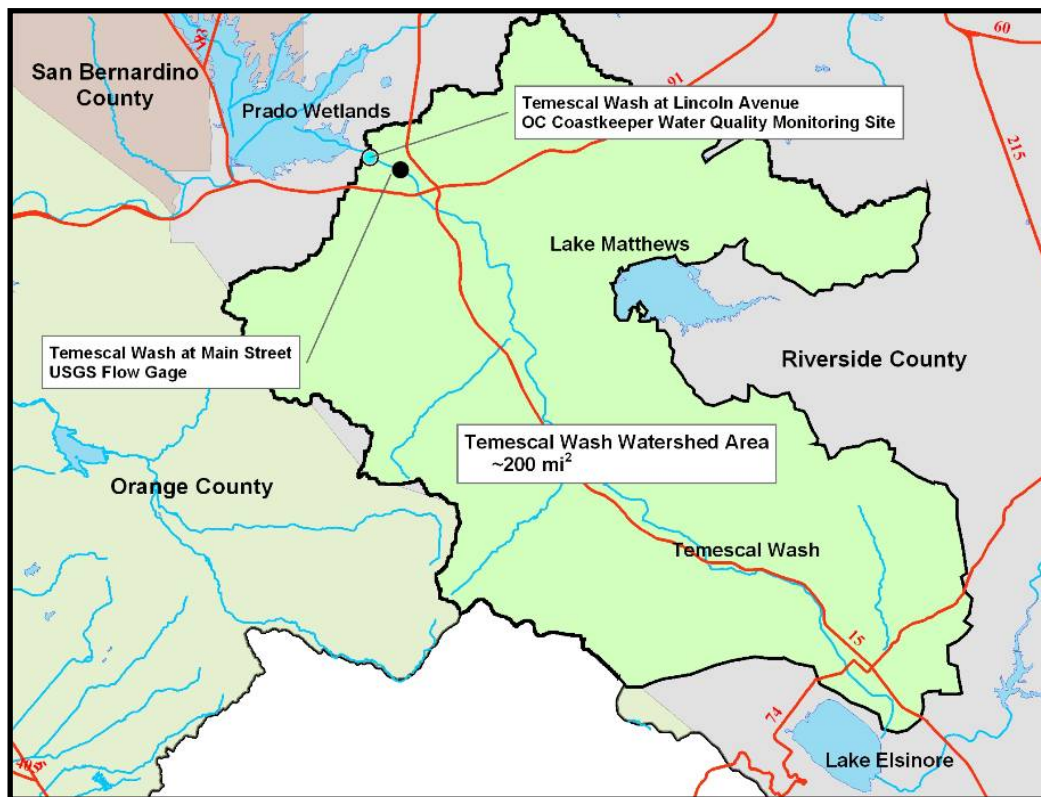

Figure 2
Map of the Temescal Wash Subwatershed

Chino Creek Subwatershed

The Chino Creek Subwatershed area (approximately 100 mi²) is comprised predominantly of residential, natural/vacant land, and commercial land with some industrial and agricultural areas (Figure 3). Water Quality data for Chino Creek were obtained and analyzed in Phase I of the SQSS. Recent (2002 to 2005) water quality samples from Chino Creek upstream of the Prado Wetlands were collected and analyzed by the Santa Ana Regional Water Quality Control Board (RWQCB) and Orange County Water District (OCWD). A total of 106 samples were collected between 2002 and 2005. Of the 106 samples, 100 were collected during dry weather and 6 during wet weather.

Flow in Chino Creek is recorded by the USGS where California State Route 71 crosses Chino Creek in Chino Hills [USGS Gage 11073360]. Available flow data from this flow gauge were processed to facilitate time series plotting and frequency distribution analysis. A multiplier equivalent to the ratio of the study subwatershed and gauged subwatershed drainage areas was applied to the flow data to estimate conditions at the point where compliance assessment was evaluated. The collected flow data was recorded in 15 minute intervals for the period between 1988 and 2005. These data are incorporated into a water quality model used to estimate a mass balance of bacteria upstream and downstream of the evaluated structural BMPs. The potential structural treatment BMP location and flow gauge are downstream of a turnout from the MWD Foothill Feeder in Upland that is used by OCWD to purchase State Project Water that is delivered down the channel and through Prado Basin to the recharge basins in Orange County. Typically, the purchases occur during the summer and result in flow that range from 50 to 200 cfs over the course of a two to eight week period.

The portion of the drainage area which lies upstream of San Antonio Dam is comprised almost entirely of natural/vacant land in the San Gabriel Mountains. Nearly all runoff from above the San Antonio Dam is captured and diverted into spreading grounds; therefore flow in Chino Creek is rarely influenced by runoff from this part of the watershed. The drainage area below the dam is a mixed land use region which is primarily residential. A potential structural BMP location is at the downstream end of Chino Creek upstream of where it flows into the Prado Wetlands.

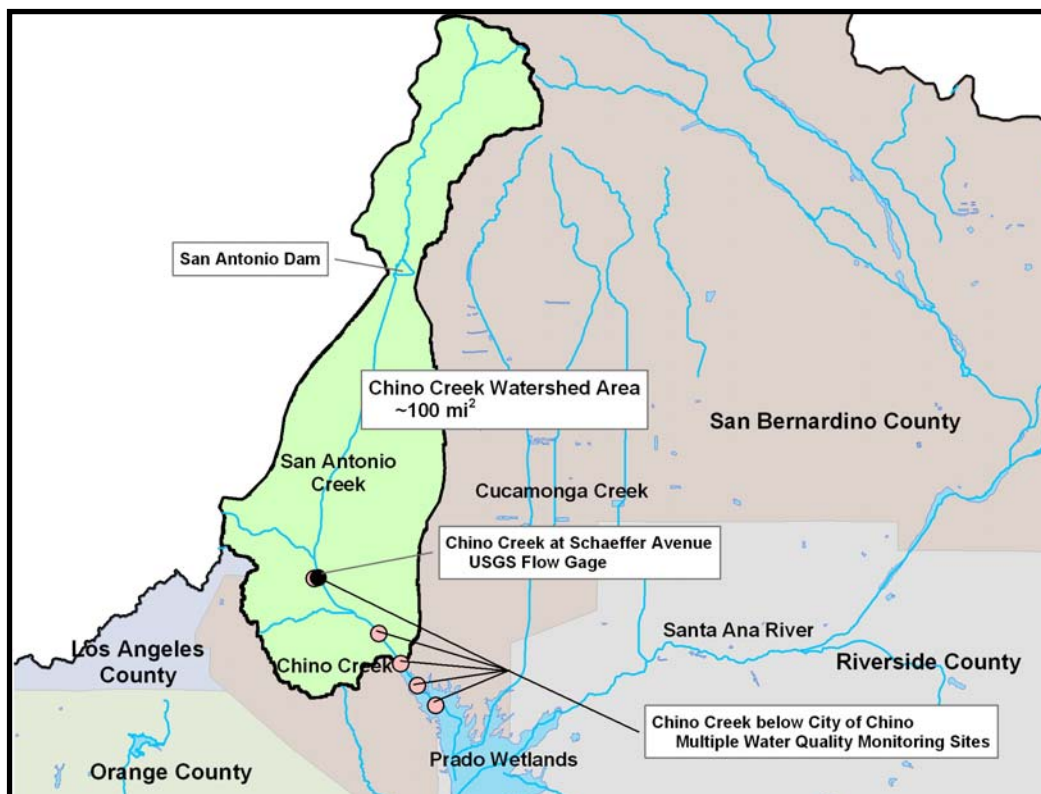

Figure 3
Map of the Chino Creek Subwatershed

Treatment Options Analysis

Structural BMPs for Bacteria Reduction

Structural BMP options that could be effective at reducing bacteria from the three study subwatersheds were identified and include:

- Constructed free surface flow wetland treatment systems
- Constructed subsurface flow wetland treatment systems
- Conventional ultraviolet light (UV) disinfection facilities
- Infiltration basins
- Dry weather diversion to existing wastewater treatment plants (WWTP)

Some of these options were determined to be infeasible in some of the study watersheds, as described later within this memorandum. All structural BMPs would be offline facilities and would therefore require diversion of flow from the channel to the treatment location. For constructed wetland and conventional UV disinfection facilities, treated water would be returned back to the channel. The nature of site requirements for these facilities will vary greatly depending upon the BMP option and site layouts. Some of the structural BMP treatment options may offer opportunities for multiple site uses (parks, recreation, parking, etc.) which may enhance their value. This level of detailed investigation was not undertaken for this technical memorandum.

Diversions could be constructed by installing inflatable rubber dams across the width of a channel. From the inflatable dam diversion, flow could be pumped and routed to an inlet channel and be screened prior to entering any of the treatment options. The maximum proposed height of the dam would be four feet to accommodate a maximum water level of three feet plus one foot of freeboard. When in use, the height of the dam and the water level maintained behind the dam may be varied and controlled based on the following conditions:

- Dry Weather Flow - Under low flow runoff conditions, a maximum depth of approximately one foot would be maintained behind the dam.
- Design Wet-Weather Flow - During design storm conditions, a depth of one to three feet could be maintained behind the dam. The dam would detain and divert all flow.
- Greater than Design Wet-Weather Flow - During large runoff events, with flows exceeding the treatment design, the dam would be automatically deflated and subsequent treatment facilities would be separated from the waterway flow by a gate. Storm flows would pass unimpeded in the channel.

General descriptions, components, and design criteria for the structural BMP options are presented in Attachment A of this technical memorandum.

Target Flow Conditions

The peak of the target runoff event was estimated for each study subwatershed by plotting the peak flowrate and average flowrate for every high flow event for the period of record at each of the subwatersheds. These plots were used to estimate an approximate peaking factor (ratio of peak flowrate to mean flowrate) at each of the pilot subwatersheds. The estimated mean daily flow and peak flow for each of the target runoff events is shown in Table 1. Target flow conditions for capture and treatment for potential structural BMPs were developed for the 0.1 and 0.5 inch rain events as well as for an event that would produce sufficient runoff to exceed a depth-velocity product of 10ft²/sec. Due to the spatial variability in rainfall patterns over large watersheds, the runoff response from similar rainfall events differ greatly. To determine an approximate rainfall based target flowrate, mean daily flows on days within 0.05 inches of the target rainfall were extracted and reviewed. A simple estimation of the total runoff volume, given an assumed runoff coefficient, for the 0.1 and 0.5 inch rain events was compared to these values and a final approximated mean daily flow for each rain event was assigned for each of the study subwatersheds (Table 1). In order to determine the mean daily flow related to the 10 ft²/sec target condition, the stream channel rating curve and cross sectional flow area was interpreted. This target flow rate for each of the study subwatersheds is also included in Table 1.

Table 1 Target Runoff Events for the Three Study Subwatersheds		
Target Condition	Mean Daily Flow (cfs)	Peak Flow (cfs)
<i>Santa Ana Delhi Channel</i>		
Rainfall Event = 0.1 inches	40	140
Depth*Velocity = 10 ft ² /sec	125	438
Rainfall Event = 0.5 inches	200	700
<i>Temescal Wash</i>		
Rainfall Event = 0.1 inches	160	480
Depth*Velocity = 10 ft ² /sec	100*	300
Rainfall Event = 0.5 inches	500	1,500
<i>Chino Creek</i>		
Rainfall Event = 0.1 inches	60	270
Depth*Velocity = 10 ft ² /sec	100	450
Rainfall Event = 0.5 inches	300	1,350

* Depth-velocity product is reached at a lower flow than the 0.1 inch rain event due to concentration of runoff in a low flow channel

Feasibility of Alternatives

Potential Sites

The structural BMP design criteria discussed in this technical memorandum were applied for each of the structural BMP options at each of the three study subwatershed locations in order to assess minimum site footprint constraints, with the exception of the dry weather diversion to wastewater treatment plant, which would not require significant land acquisition. Infiltration basins and constructed wetlands will require a significantly larger area than conventional disinfection treatment systems to provide the capacity to capture and treat stormwater. The potential for dry weather diversion to existing WWTPs was discussed with respective local wastewater agencies.

Aerial photographs were reviewed and open space areas that could potentially be acquired and utilized for structural BMPs were identified for the Santa Ana Delhi Channel, Temescal Wash, and Chino Creek subwatersheds, shown in Figures 4 through 6, respectively. Potentially available land included 11 acres near the Santa Ana Delhi Channel, 42 acres near Temescal Wash, and 163 acres near Chino Creek. The primary criterion was to identify open land in the general vicinity of the channel sites that does not currently have significant fixed development. The sites may have other existing or potential uses. Therefore, it should be clear that this exercise was conducted for the purpose of developing this preliminary economic analysis only and is not intended to suggest that the sites are actually available, without significant additional investigation.



Figure 4
Potential Structural BMP Site for the Santa Ana Delhi Subwatershed



Figure 5
Potential Structural BMP Site for the Temescal Wash Subwatershed



Figure 6
Potential Structural BMP Site for the Chino Creek Subwatershed

Constructed Free Surface Flow Wetlands

A constructed free surface flow (FSF) wetland must be sized to handle flow under both dry-weather and wet-weather conditions. In order to achieve a 7 day residence time for the flow expected to reach the treatment area, the capacity of the wetland must be sufficient for 7 days worth of combined dry- and wet-weather flow. A wetland can be designed as a single plane or with multiple tiers to provide treatment for varying levels of flow. A two-tier system has been used for design for this analysis, with a 1 ft deep inner dry-weather channel and a larger flood channel 1.5 ft deep surrounding it, to support the additional wet-weather flow input. The site footprints required for treatment within a FSF wetland for each channel for three target runoff conditions are summarized in Table 2.

Table 2 Summary of Constructed Free Surface Flow Wetland System Design Parameters						
Scenario	Flow Rate [cfs]	7-day Volume[MG]	Wetland Footprint [ac]	Length [ft]	Width [ft]	
<i>Santa Ana Delhi Channel</i>						
Rainfall Event = 0.1 inches	40	113	231	7,780	1,300	
Depth*Velocity = 10 ft ² /sec	125	498	1,018	16,310	2,720	
Rainfall Event = 0.5 inches	200	837	1,712	21,160	3,530	
<i>Temescal Wash</i>						
Rainfall Event = 0.1 inches	160	271	555	12,050	2,010	
Depth*Velocity = 10 ft ² /sec	100	543	1,111	17,040	2,840	
Rainfall Event = 0.5 inches	500	2,081	4,258	33,360	5,560	
<i>Chino Creek</i>						
Rainfall Event = 0.1 inches	60	226	463	11,000	1,830	
Depth*Velocity = 10 ft ² /sec	100	407	833	14,760	2,460	
Rainfall Event = 0.5 inches	300	1,312	2,684	26,490	4,410	

A length to width ratio of 6 to 1 is desired for this design. In most scenarios, the length to width ratio would be greater under dry-weather conditions because the dry-weather channel would be constructed along the full length of the wetland, but would not require the same total area. However for Temescal Wash, the dry-weather channel controls the wetland size for the 0.1 in. storm. The dimensions required for the treatment wetlands to meet this criterion are found in Table 2.

As a result of this analysis, the minimum wetland footprint area for any stormwater treatment scenario at any of the three sites is greater than the space that could become available and therefore no FSF constructed wetland alternative is considered feasible.

Subsurface Flow Wetlands

A subsurface flow wetland must be sized to capture the target flow conditions, with additional detention storage to accommodate the peak flow from the rainfall event. Approximately 0.33 MGD of hydraulic loading can be treated by one acre of subsurface flow wetlands with a 48 hour residence time (USEPA, 1993). Based on this land requirement, a SSF wetland may only be feasible for the 0.1 inch storm at Chino Creek (Table 3). Larger storms at Chino Creek and 0.1 inch and larger storms at Temescal Wash and Santa Ana Delhi Channel all require larger footprints than the identified sites.

Table 3 Summary of Subsurface Flow Wetland System Design Parameters				
Scenario	Flow Rate [cfs]	Wetland Footprint [ac]	Detention Footprint [ac]	Total Footprint [ac]
<i>Santa Ana Delhi Channel</i>				
Rainfall Event = 0.1 inches	40	78	1	79
Depth*Velocity = 10 ft ² /sec	125	243	2	245
Rainfall Event = 0.5 inches	200	388	6	394
<i>Temescal Wash</i>				
Rainfall Event = 0.1 inches	160	310	4	315
Depth*Velocity = 10 ft ² /sec	100	194	3	197
Rainfall Event = 0.5 inches	500	970	13	983
<i>Chino Creek</i>				
Rainfall Event = 0.1 inches	60	116	2	119
Depth*Velocity = 10 ft ² /sec	100	194	4	198
Rainfall Event = 0.5 inches	300	608	11	618

Conventional Disinfection Facility (Ultra-violet Disinfection)

Site constraints related to treatment using conventional disinfection are primarily a function of the space available to provide detention storage of the volume of flow during the part of a storm event that occurs above the capacity of the disinfection system. Technical Release 55 (USDA Soils Conservation Service Engineering Division, 1986) was used to calculate the storage necessary given a peak flowrate and treatment outflow. Table 4 presents the storage volumes that would be necessary to capture runoff, if the UV disinfection system treatment rate is one half of the mean event daily flow. This treatment rate would provide a 48 hour drawdown of the target runoff event. The conventional disinfection plant will require a much smaller footprint than the detention storage and was assumed to be approximately ½ to 1 acre. Based on this feasibility assessment, there is sufficient space (assuming property can be acquired) to capture and treat runoff from all targeted flow conditions for each of the study subwatersheds.

Table 4 Summary of Conventional Disinfection System Preliminary Design				
Scenario	Treatment Rate [cfs]	Storage Volume (ac-ft)	Detention Depth* (ft)	Footprint** (ac)
<i>Santa Ana Delhi Channel</i>				
Rainfall Event = 0.1 inches	20	36	20	3
Depth*Velocity = 10 ft ² /sec	63	112	20	7
Rainfall Event = 0.5 inches	100	179	20	11
<i>Temescal Wash</i>				
Rainfall Event = 0.1 inches	80	130	20	8
Depth*Velocity = 10 ft ² /sec	50	81	20	5.5
Rainfall Event = 0.5 inches	250	407	20	23
<i>Chino Creek</i>				
Rainfall Event = 0.1 inches	30	58	20	4
Depth*Velocity = 10 ft ² /sec	50	97	20	6.5
Rainfall Event = 0.5 inches	150	292	20	17

*Includes 2 feet of freeboard

**Includes detention tank plus 1 acre for treatment equipment

Infiltration Basin

An infiltration basin must be sized to accommodate the total runoff volume expected to be diverted from the channel and have the infiltration capacity to draw down the volume of runoff in the basin within 48 hours. Assuming even a moderately high infiltration capacity (2 ft/day) at each of the potential structural BMP potential locations, the available space for an infiltration basin would not be large enough to infiltrate the runoff from even the 0.1 inch storm event from the Santa Ana Delhi Channel or Temescal Wash subwatersheds within 48 hours. These sites would have to be 20 acres and 79 acres, respectively to capture the 0.1 inch storm flow runoff. Furthermore, soils in the lower portion of the Santa Ana Delhi Channel are not conducive for even moderate infiltration rates.

The potential land available for the Chino Creek study subwatershed is 163 acres, however only a portion of the parcel is suitable for infiltration. The soil within this parcel is a mixture of Grangeville Fine Sandy Loam, Chino Silt Loam, and Sorrento Clay Loam. Of these soil types, only the Grangeville Fine Sandy Loam is suitable for infiltration, with an estimated infiltration rate up to 2 ft/day. The potential BMP location includes approximately 42 acres of this soil type and therefore approximately 25% of the total area is suitable for an infiltration basin. Based on the required footprints for each target storm event, providing stormwater treatment through infiltration will be an option only for the runoff from the 0.1 inch rainfall event (Table 5). The maximum treatable flow rate in this case is approximately 85 cfs.

Table 5 Summary of Infiltration Basin Design Parameters				
Scenario		Flow Rate [cfs]	Volume [MG]	Footprint [ac]
<i>Santa Ana Delhi Channel</i>				
	Rainfall Event = 0.1 inches	40	26	20
	Depth*Velocity = 10 ft ² /sec	125	81	62
	Rainfall Event = 0.5 inches	200	129	99
<i>Temescal Wash</i>				
	Rainfall Event = 0.1 inches	160	103	79
	Depth*Velocity = 10 ft ² /sec	100	65	50
	Rainfall Event = 0.5 inches	500	323	248
<i>Chino Creek</i>				
	Rainfall Event = 0.1 inches	60	39	30
	Depth*Velocity = 10 ft ² /sec	100	65	50
	Rainfall Event = 0.5 inches	300	194	149

Dry-Weather Diversion to Existing WWTP

Dry-weather flow diversion to an existing WWTP could potentially be feasible for the Santa Ana Delhi Channel subwatershed. Dry weather runoff (<4 cfs) could be diverted from the Santa Ana Delhi Channel to Orange County Sanitation District (OCSD)'s Huntington Beach facility, which has a capacity to accept up to of 10 MGD (15 cfs) of dry weather flow. OCSD is currently treating dry weather urban runoff from the Greenville Banning Channel and other storm drains in Orange County. The facilities are currently receiving flows of 4 MGD (6.2 cfs), and can accept up to an additional 6 MGD (9.3 cfs) of dry weather runoff from the Santa Ana Delhi Channel and/or others.

The likely WWTP for diversion of the Temescal Wash flow would be the City of Corona's Plant No. 2; however the dry-weather flow rate requiring diversion is significantly greater than the plant's rated capacity. The point along Chino Creek where dry weather runoff could be diverted is closest to the Inland Empire Utility Agency (IEUA) Regional Plant No. 5; however IEUA has expressed plans to allow the plant's maximum capacity to be reached through new residential development.

Water Quality Modeling

Overview

The processes driving bacteria water quality levels are complex and difficult to define. However, measured data during a variety of flow conditions and seasons exist for all three of the sites of interest in this study. For these reasons, a probabilistic approach was taken to modeling stream bacteria levels in the three target sites. Rather than trying to numerically represent mechanistic processes associated with stream bacteria levels, this approach instead focuses on maximizing the use of the available measured data and incorporating the uncertainty associated with these data.

Probability density functions (PDFs) were fitted to measured site-specific bacteria data. These functions were then incorporated into a Monte Carlo simulation which samples the PDFs thousands of times to generate "upstream" bacteria loads. The upstream loads are used in simple mass balance calculations to estimate a distribution of expected downstream concentrations as a function of user-defined treatment scenarios. The Excel add-in software @Risk (Palisade Inc.) was used for both the probability curve fitting and the Monte Carlo simulations.

Bacteria PDFs

@Risk was used to fit the PDFs to measured bacteria concentration data (Fecal coliform or *E. coli*) at each target site. All available data back to 1990 were used for these analyses. Function types were not pre-defined. @Risk uses the "Maximum Likelihood Estimator" approach to fit functions to sample data, as described in the software user's manual (Palisade, 2005). Table 6 summarizes the results of this function-fitting exercise. The fitted curves are shown in Figure 7.

Table 6			
Fitted Bacteria Concentration Probability Density Functions			
	<i>Santa Ana Delhi Channel</i>	<i>Temescal Wash</i>	<i>Chino Creek</i>
<i>Bacteria</i>	Fecal coliform	<i>E. coli</i>	Fecal coliform
<i>Period of Record</i>	1990 – 2004	2002 – 2004	2002 - 2004
<i>Number of Data Points</i>	419	28	106
<i>Fitted Function</i>	Exponential	Inverse Gaussian	Inverse Gaussian
<i>Function Parameters</i>	m = 9378, s = 513, shift = -48	b = 393, shift = -14	m = 1385, s = 252, shift = -24

Flow Correlations

Analyses were performed to investigate the possibility of correlations between mean daily flow and expected bacteria concentrations. If present, these types of correlations could be incorporated into the Monte Carlo modeling of stream water quality.

Regressions were performed on the bacteria concentration and associated mean daily flow matched pairs to investigate correlations. Both parametric (Pearson) and non-parametric (Spearman Rank) analyses were performed for all three sites. The parametric analysis assumes any relationship between the data is linear. The non-parametric analysis only takes into account the relative order, or rank, of the data and does not assume a form of the relationship a priori. No significant ($p \leq 0.05$) correlations were found for any of the three sites. R^2 and p values for these analyses are summarized in Table 7.

In addition to these tests, a threshold flow analysis was performed. It was desired to test whether the mean bacteria concentration for baseflow conditions was significantly lower than that for non-baseflow conditions. Baseflow, for this exercise, was determined to be equal to the point of inflection in the flow duration curve for each of the three study flow data records. Both arithmetic and geometric means for the data subsets were calculated and compared between baseflow and non-baseflow samples. For two of the sites (Santa Ana Delhi and Chino Creek), the mean bacteria concentration was actually higher in the baseflow set. For Temescal Wash, there was not sufficient wet weather sampling conducted to attempt any statistical correlation analyses. The results of these analyses are also included in Table 7. Based on these results, no correlations between flow and expected bacteria concentration were incorporated into the water quality modeling described below.

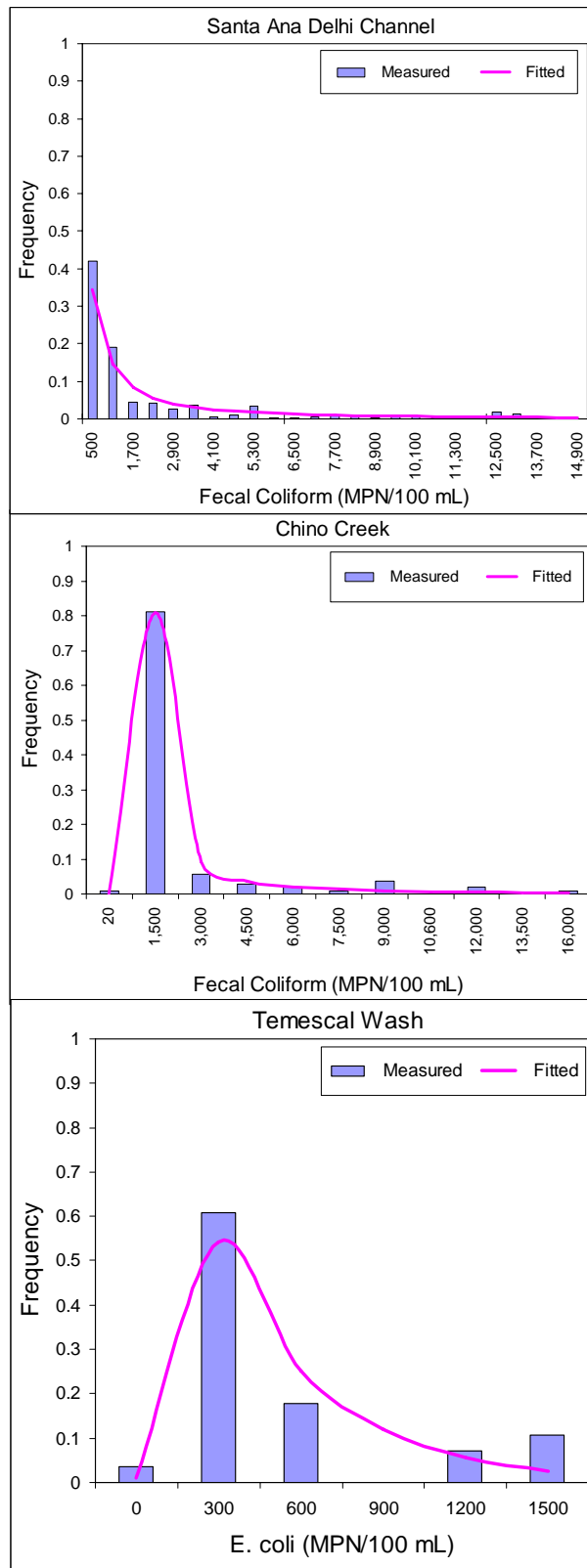

Figure 7
Fitted Bacteria Probability Distribution Functions

		<i>Santa Ana Delhi Channel (FC)</i>	<i>Temescal Wash (EC)</i>	<i>Chino Creek (FC)</i>
<i>Pearson R², p</i>		-0.03, 0.5	0.09, 0.11	0.01, 0.23
<i>Spearman R², p</i>		-0.07, 0.13	0.01, 0.59	0.02, 0.20
<i>Baseflow Threshold (cfs)</i>		15	40	10
<i>Baseflow Bacteria Concentration (#/100 ml)</i>	<i>Arithmetic Mean</i>	8,056	377	1,430
	<i>Geometric Mean</i>	1,072	239	408
<i>Non-baseflow Bacteria Concentration (#/100 ml)</i>	<i>Arithmetic Mean</i>	3,533	1,220	232
	<i>Geometric Mean</i>	821	1,220 (n=1)	161(n=6)

Water Quality Model: Approach

A water quality model was constructed to quantify anticipated existing water quality (bacteria) at the three target sites and allow for the estimation of the impacts of the various BMP options previously discussed on downstream bacteria water quality levels. In this way, the model is meant to provide preliminary support to the design of site-specific BMP options and provide an estimate of resulting water quality improvements. The model is constructed in Microsoft Excel and predicts downstream bacteria water quality at a daily timestep for a period of 1 year.

Simple mass and flow balance calculations were used to estimate downstream concentrations as a function of sampled upstream concentrations and user-specified flows and BMP options. Upstream concentrations are sampled from the probability density functions described above. Monte Carlo simulations are performed, using @Risk, which sample upstream PDFs one thousand (1000) times for each day of the simulation. At each iteration, full model calculations are performed resulting in a daily timeseries of expected concentrations. Daily bacteria cumulative density functions (CDFs) are formulated by the software and output to separate worksheets. As a post-processing step, these daily CDFs are pooled to get an annual representation of expected bacteria water quality. Final results are presented in the form of exceedence probability plots.

Two categories of BMP options that capture, treat and return the treated flow to the receiving water can be approximated in the model: batch reactor (storage and discharge) such as a conventional disinfection facility; and plug flow (flow-through system) such as a constructed wetland. For the batch reactor BMP type, a user-specified portion of flow (defined by a minimum and a maximum) is diverted from the target stream and delivered to storage. The diverted water is detained in storage as a function of user-defined parameters (storage capacity, minimum pool, and outflow). While in storage, a user-defined first-order removal rate is applied, with the final outflow concentration calculated as a function of the removal rate and system detention time. Alternatively, target outflow concentrations can be explicitly

defined by the user. Outflow can then be routed back to the stream, where it is mixed with any undiverted flow, or can be assumed to leave the system completely. For plug flow BMPs, diverted flow moves through a removal system parameterized by a user-defined removal efficiency (%). Residence time is also user-defined and provides the lag realized between inflow and outflow. Lagged outflows are then combined with undiverted stream flow or can be assumed to leave the system completely.

For BMP options that do not return flow to the system (infiltration, dry weather flow diversion), flows and loads are removed from the stream according to user-defined minimum and maximum criteria. No portion of the diverted flow or load is returned to the system. Therefore, water quality calculations are performed on the remaining instream flow only. If 100% of flow is diverted on a given day, the associated downstream concentration is represented as 0 in the final model CDF.

Water Quality Model: Inputs

The initial objective was to simulate runoff from the year with the highest total annual flow (back to 1990) for each site, to provide the daily time series of model flow. The approach was used for the Santa Ana Delhi Channel (year 1998). For the Chino Creek site, the year with the highest total annual flow (1995) was initially considered, but this included a substantial release water of State Project Water for spreading in Orange County and was eliminated from consideration. The year with the highest total annual natural flow (1993) was used. Local USGS flow gage data were the source for daily flows: Santa Ana Delhi Channel near Irvine Ave., Temescal Creek above Main Street, and Chino Creek at Schaeffer Ave.

Only those BMP options deemed feasible (as discussed in the preceding section of this TM) were modeled here. These options are summarized in Table 8. Targeted diversion flows were set based on an analysis of site specific hydrologic and precipitation data as discussed in the target flow conditions section of this technical memorandum. For the conventional detention and UV disinfection option, return flow concentrations in the model are assumed to be equal to the appropriate instream water quality objective (200MPN/100mL for fecal coliform and the recommended 135 MPN/100mL for *E. coli*). For the diversion to sanitary and infiltration options, no return flows or loads are modeled. Wetland return flow concentrations are based on a percent removal and are dependent on the influent concentration and therefore may be above the standards. Estimates for effluent concentrations were made for these cursory evaluations, however in reality, bacteria concentrations in the treated effluent may vary significantly, particularly for treatment by natural processes, such as wetlands. Also, there is the possibility for regrowth and increased bacteria concentration after the effluent has been returned to the channel that has not been incorporated.

Table 8 Summary of Modeled BMP Options			
Subwatershed	Alternative	Key Parameters	Comments
Santa Ana Delhi Channel	Conventional Detention & UV Disinfection	Diversion Capacity= 40, 200 cfs; Treatment Capacity = 20, 100 cfs ; Residence Time = 1 Day;	Treated to instream objective; Discharge back to stream at point of diversion.
Santa Ana Delhi Channel	Dry Weather Diversion to Offsite Sanitary Treatment Facility	Max diversion = 4 cfs	No return flows or loads
Temescal Wash	Conventional Detention & UV Disinfection	Diversion Capacity = 100, 500 cfs; Treatment Capacity = 50, 250 cfs ; Residence Time = 1 Day;	Treated to instream objective; Discharge back to stream at point of diversion.
Chino Creek	Conventional Detention & UV Disinfection	Diversion Capacity = 60, 300 cfs; Treatment Capacity = 30, 150 cfs ; Residence Time = 1 Day;	Treated to instream objective; Discharge back to stream at point of diversion.
Chino Creek	Infiltration	Diversion Capacity = 60 cfs	No return flows or loads
Chino Creek	Subsurface Flow Wetland	Diversion Capacity = 60 cfs Residence Time = 1 Day Removal Efficiency = 70%	Subsurface wetland; Discharge back to stream at point of diversion

Results

Model simulation results are presented in Figures 8 through 10 for the Santa Ana Delhi Channel, Temescal Wash, and Chino Creek subwatersheds, respectively. The results of the water quality model simulations are presented as cumulative distribution functions to show the probability of exceeding bacteria water quality objectives. Results show that the evaluated structural BMPs reduce bacteria exceedences from each of the subwatersheds. The results from the Temescal Wash study subwatershed are somewhat different than Chino Creek and Santa Ana Delhi Channel, in that a greater probability of exceedence was predicted. This was due to elevated baseflow in Temescal Wash following the winter of 1994-1995. Flow was above the diversion thresholds over an extended period during March and April.

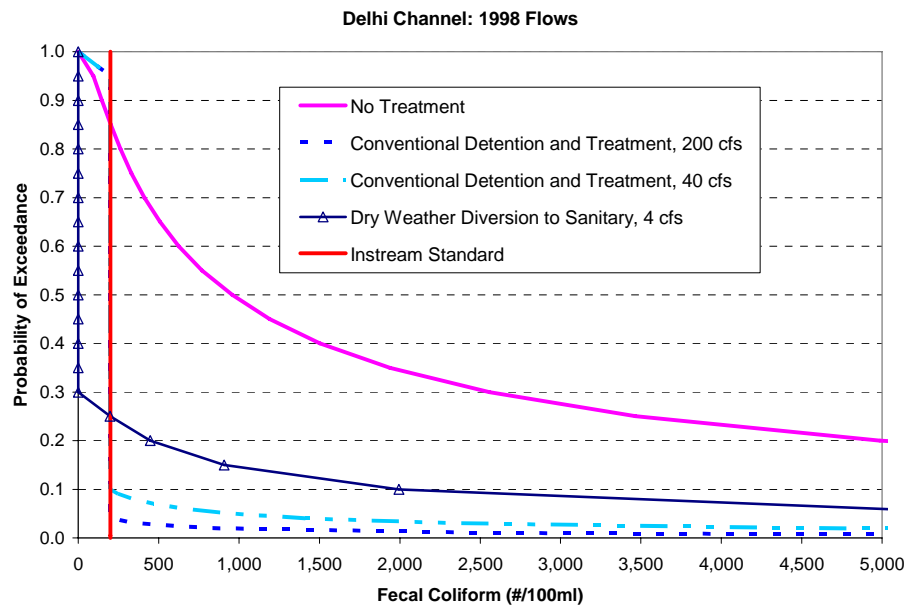

Figure 8
 Results of the Water Quality Model for the Santa Ana Delhi Channel Subwatershed - Cumulative Distribution Functions

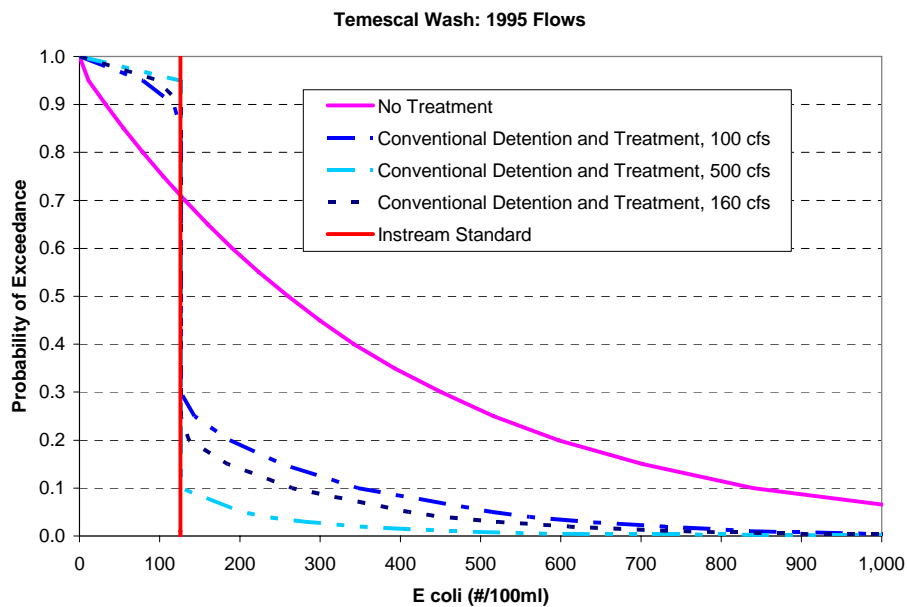

Figure 9
 Results of the Water Quality Model for the Temescal Wash Subwatershed - Cumulative Distribution Functions

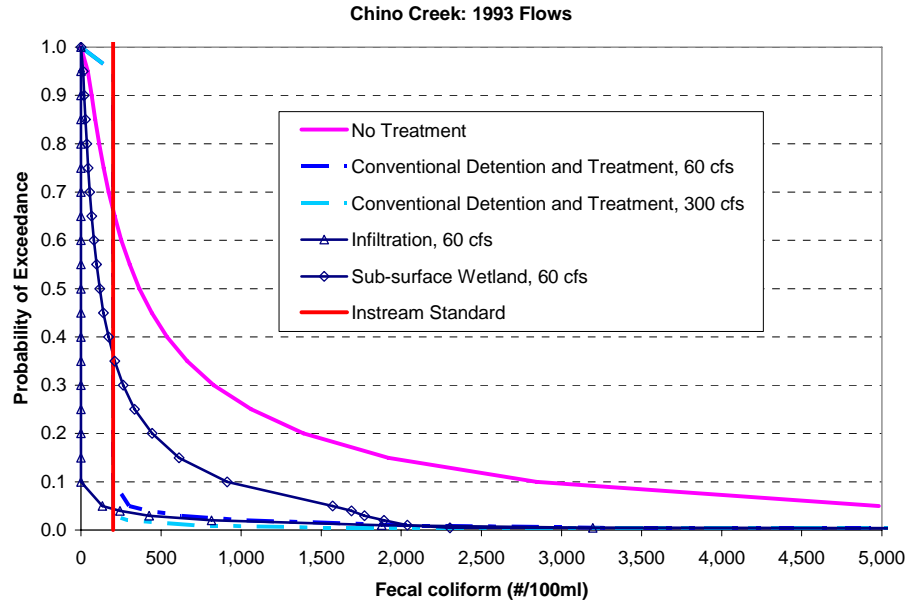

Figure 10
Results of the Water Quality Model for the Chino Creek
Subwatershed - Cumulative Distribution Functions

The average number of days that flow would bypass the treatment options based on review of long term year flow records from each of the study sites is presented in Table 9. The results of the water quality model showed that bacteria water quality conditions on these high flow days will likely exceed the current REC-1 use objectives.

Table 9 Average Annual Number of Days without Treatment				
Scenario	Constructed Wetland	Conventional Disinfection	Infiltration Basin	Dry Weather Diversion
<i>Santa Ana Delhi Channel</i>				
Dry Weather Flow	N	N	N	76
Rainfall Event = 0.1 inches	I	16	I	N/A
Depth*Velocity = 10 ft ² /sec	I	7	I	N/A
Rainfall Event = 0.5 inches	I	4	I	N/A
<i>Temescal Wash</i>				
Dry Weather Flow	N	N	N	N
Rainfall Event = 0.1 inches	I	9	I	N/A
Depth*Velocity = 10 ft ² /sec	I	16	I	N/A
Rainfall Event = 0.5 inches	I	2	I	N/A
<i>Chino Creek</i>				
Dry Weather Flow	N	N	N	N
Rainfall Event = 0.1 inches	38	38	38	N/A
Depth*Velocity = 10 ft ² /sec	I	19	I	N/A
Rainfall Event = 0.5 inches	I	2	I	N/A

* I = Infeasible, N = Not Evaluated

Potential reductions in the probability of exceeding objectives can be accounted for by the fact that stormwater runoff that bypasses treatment during high flow events will be diluted by effluent returning to the channel from the BMP alternatives (conventional disinfection and constructed wetland options only discharge treated runoff back to the channel), along with days that the water quality model predicted a lower bacteria concentration

Economic Assessment

An economic assessment was conducted only for those structural BMP control options deemed feasible based on the identified constraints for each study subwatershed. The costs reported here were developed based on conceptual level designs and are intended to be used only as a general planning tool.

Costs were estimated on both a total and per capita level based on an estimate of the population within each subwatershed. Additionally, a factor of 3.1 persons/household was used to estimate the cost per household for each of the feasible BMPs (University of Southern California, Southern California Studies Center, 2001). Watershed populations were estimated based on 2000 Census data for the portion of cities and unincorporated capital cost estimates that lie within each subwatershed. The population for each city and unincorporated area within the watershed was estimated by multiplying the total population estimate by the approximate percentage of city land contained within the watershed boundary (Table 10).

Costs associated with land acquisition were not included in the capital cost estimates; because the sites are all within publicly owned lands and actual costs may vary significantly. Based upon a review of available non-residential lands for sale in the cities where projects may be located, the following normalized costs could be expected:

- Santa Ana Delhi Channel (City of Santa Ana) - \$2,800,000/acre
- Temescal Wash (City of Corona) - \$750,000/acre
- Chino Creek (City of Chino) - \$650,000/acre

All of the alternatives would require a diversion structure within the channel. This preliminary assessment assumed that an inflatable dam would be utilized. The cost of an inflatable dam would be similar for all 3 subwatersheds, and was estimated by updating costs from a study developed for the City of Los Angeles Ballona Creek Treatment Facility Feasibility Study (City of Los Angeles, 1996) to reflect current costs by utilizing the Engineering News Records (ENR) Construction Cost Index.

Table 10			
Population Estimates for the Three Study Subwatersheds			
City	Total Population	Approximate Population with Subwatershed	Estimated Households within a Subwatershed*
<i>Santa Ana Delhi Channel</i>			
Santa Ana	337,977	159,706	51,518
Costa Mesa	108,724	43,440	14,013
Newport Beach	70,032	554	179
Irvine	143,072	146	47
Orange	128,821	53	17
Total		203,898	65,774
<i>Temescal Wash</i>			
Corona	124,966	94,124	30,363
Riverside	255,166	58,758	18,954
Home Gardens	9,461	9,461	3,052
Lake Elsinore	28,928	7,342	2,368
Norco	24,157	5,915	1,908
El Cerrito	4,590	4,343	1,401
Woodcrest	8,342	3,846	1,241
Total		183,789	59,287
<i>Chino Creek</i>			
Pomona	149,473	79,336	149,473
Chino	67,168	51,292	67,168
Chino Hills with Los Serranos	66,787	48,517	66,787
Upland	68,393	34,226	68,393
Montclair	33,049	33,122	33,049
Ontario	158,007	25,761	158,007
Claremont	33,998	21,242	33,998
Diamond Bar	56,287	2,434	56,287
San Antonio Heights	3,122	615	3,122
Total		296,546	95,660

* Approximate population divided by 3.1 persons per household

Conventional Disinfection Facility

Ultra-Violet Disinfection (UV) facilities coupled with other pre-treatment are assumed to be feasible at Temescal Wash, Santa Ana Delhi Channel, and Chino Creek. Costs for UV treatment systems include capital costs and operation and maintenance costs (O&M). Capital costs include inflatable dams, diversion from the channel, filtration systems detention tanks, pump stations, screens, and the UV system. Annual O&M costs include labor, maintenance, and energy costs. Capital costs for underground detention storage tanks, influent and effluent channels, and pump stations were estimated by assuming the tanks would be reinforced concrete. Contingencies for construction, field and home office overhead and insurance were included in the estimates. Tables 11 through 13 summarize the costs for

conventional UV disinfection systems at the three study sites for runoff resulting from the 0.1 and 0.5 inch rainfall events, as well as the runoff resulting in flow reaching a depth-velocity product of 10 ft²/sec.

Capital costs for pump stations were based on several design and unit cost assumptions including a total head loss 30 ft to account for the elevation head and flow through a sand filter, 75% pump efficiency, and station cost of \$1,500 per pump horse power. Vendor supplied costs of \$60,000/mgd of capacity for equipment and an additional \$30,000/mgd for concrete and installation were used to estimate the cost for filters operating at 6 gpm/ft². Capital costs for the conventional UV disinfection treatment system include costs for equipment and disinfection channels. The equipment includes the frame, Low Pressure High Output (LPHO) lamps, quartz sleeves for lamps, ballasts, power supplies for ballasts, and mechanical and chemical cleaning systems. The dimensions of the channels that would be used to concentrate flow for UV irradiation include the width, length and number of channels. The treatment system designs were used to estimate the probable cost of construction for each site's conveyance structures for each of the target flow conditions. Several assumption were made to develop probable costs of construction for the various conveyance structures for each of the sites, including close proximity of the detention tank to the inflatable dam turnout (500 ft), and close proximity of the effluent channel to the point where flow is released back into the channel (500 ft).

Historical flow records from each site were used to determine the average annual volume of runoff that would be diverted and treated in a conventional disinfection facility. This volume was used to estimate energy usage costs for UV irradiation and pumping. Annual energy costs for UV radiation were estimated based on peak power draw unit costs provided by the UV vendor and an assumed rate of 15 cents per kWh. Average annual energy costs for the pump stations were estimated by calculating energy usage over a typical year using the assumed rate of 15 cents per kWh.

Infiltration Basin

As noted earlier, given local soil and site attainability limitations, an infiltration basin is feasible only for the runoff from the 0.1 inch rainfall event for the Chino Creek study subwatershed. Capital Costs for the infiltration basins include construction of the basins construction of a pump station and diversion structures; O&M costs including occasional sediment removal, energy usage for pumping, and diversion structure maintenance.

Capital costs for a pump station and influent conveyance channels were based on design and unit cost assumptions including a total head loss 20 ft, 75% pump efficiency, and station cost of \$1,500 per pump horse power, and 500 ft distance from the pump station to the infiltration basin. Table 14 summarizes the capital and O&M costs for an infiltration basin at the Chino Creek study site for the 0.1 inch rainfall event.

Table 11				
Summary of Opinion of Probable Costs for Capital and O&M for Conventional Detention and UV Disinfection System at the Santa Ana Delhi Channel Study Site				
Santa Ana Delhi Channel - 0.5 inch Rainfall (200 cfs, 24 hr average)				
Capital Cost	Total	Per Capita	Per Household	
Inflatable Dam	\$530,000	\$2.60	\$8.06	
Diversion Culvert	\$1,700,000	\$8.30	\$25.73	
Underground Detention Storage	\$90,000,000	\$441.40	\$1,368.34	
Pump Station	\$4,500,000	\$22.10	\$68.51	
Filters	\$15,000,000	\$73.60	\$228.16	
UV Disinfection System	\$3,500,000	\$17.20	\$53.32	
Discharge Culvert	\$500,000	\$2.50	\$7.75	
	Total	\$115,730,000	\$568	\$1,760
Annual O&M Cost				
Labor and Materials	\$450,000 /yr	\$2.20	\$6.82	
Energy for UV Irradiation	\$20,000 /yr	\$0.10	\$0.31	
Energy for Pumping	\$35,000 /yr	\$0.20	\$0.62	
	Total	\$505,000/yr	\$2.50/yr	\$7.75/yr
Santa Ana Delhi Channel - 10 ft²/sec Runoff Condition (125 cfs, 24 hr average flow)				
Capital Cost	Total	Per Capita	Per Household	
Inflatable Dam	\$530,000	\$2.60	\$8.06	
Diversion Culvert	\$1,500,000	\$7.40	\$22.94	
Underground Detention Storage	\$55,000,000	\$269.70	\$836.07	
Pump Station	\$2,500,000	\$12.30	\$38.13	
Filters	\$6,500,000	\$31.90	\$98.89	
UV Disinfection System	\$3,000,000	\$14.70	\$45.57	
Discharge Culvert	\$450,000	\$2.20	\$6.82	
	Total	\$69,480,000	\$341	\$1,056
Annual O&M Cost				
Labor and Materials	\$280,000 /yr	\$1.40	\$4.34	
Energy for UV Irradiation	\$13,000 /yr	\$0.10	\$0.31	
Energy for Pumping	\$28,000 /yr	\$0.10	\$0.31	
	Total	\$321,000/yr	\$1.60/yr	\$4.96/yr
Santa Ana Delhi Channel - 0.1 inch Rainfall (40 cfs, 24 hr average flow)				
Capital Cost	Total	Per Capita	Per Household	
Inflatable Dam	\$530,000	\$2.60	\$8.06	
Diversion Culvert	\$1,000,000	\$4.90	\$15.19	
Underground Detention Storage	\$20,000,000	\$98.10	\$304.11	
Pump Station	\$1,500,000	\$7.40	\$22.94	
Filters	\$2,500,000	\$12.30	\$38.13	
UV Disinfection System	\$1,500,000	\$7.40	\$22.94	
Discharge Culvert	\$300,000	\$1.50	\$4.65	
	Total	\$27,330,000	\$134	\$415
Annual O&M Cost				
Labor and Materials	\$150,000/yr	\$0.70	\$2.17	
Energy for UV Irradiation	\$10,000/yr	\$0.00	\$0.00	
Energy for Pumping	\$20,000/yr	\$0.10	\$0.31	
	Total	\$180,000/yr	\$0.90/yr	\$2.79/yr

Table 12			
Summary of Opinion of Probable Costs for Capital and O&M for Conventional Detention and UV Disinfection System at the Temescal Wash Study Site			
Temescal Wash - 0.5 inch Rainfall (500 cfs, 24 hr average flow)			
Capital Cost	Total	Per Capita	Per Household
Inflatable Dam	\$530,000	\$2.90	\$8.99
Diversion Culvert	\$3,000,000	\$16.30	\$50.53
Underground Detention Storage	\$190,000,000	\$1,033.80	\$3,204.78
Pump Station	\$10,000,000	\$54.40	\$168.64
Filters	\$25,000,000	\$136.00	\$421.60
UV Disinfection System	\$7,500,000	\$40.80	\$126.48
Discharge Culvert	\$700,000	\$3.80	\$11.78
Total	\$ 236,730,000	\$1,288	\$3,993
Annual O&M Cost			
Labor and Materials	\$900,000	\$4.90	\$15.19
Energy for UV Irradiation	\$50,000	\$0.30	\$0.93
Energy for Pumping	\$150,000	\$0.80	\$2.48
Total	\$1,100,000	\$6.00	\$18.60
Temescal Wash - 10 ft²/sec Runoff Condition (100 cfs, 24 hr average flow)			
Capital Cost	Total	Per Capita	Per Household
Inflatable Dam	\$530,000	\$2.90	\$8.99
Diversion Culvert	\$1,300,000	\$7.10	\$22.01
Underground Detention Storage	\$29,000,000	\$157.80	\$489.18
Pump Station	\$2,500,000	\$13.60	\$42.16
Filters	\$5,500,000	\$29.90	\$92.69
UV Disinfection System	\$3,000,000	\$16.30	\$50.53
Discharge Culvert	\$330,000	\$1.80	\$5.58
Total	\$42,160,000	\$229	\$711
Annual O&M Cost			
Labor and Materials	\$250,000/yr	\$1.40	\$4.34
Energy for UV Irradiation	\$35,000/yr	\$0.20	\$0.62
Energy for Pumping	\$80,000/yr	\$0.40	\$1.24
Total	\$365,000/yr	\$2.00/yr	\$6.20/yr
Temescal Wash - 0.1 inch Rainfall (160 cfs, 24 hr average flow)			
Capital Cost	Total	Per Capita	Per Household
Inflatable Dam	\$530,000	\$2.90	\$8.99
Diversion Culvert	\$1,500,000	\$8.20	\$25.42
Underground Detention Storage	\$50,000,000	\$272.10	\$843.51
Pump Station	\$4,000,000	\$21.80	\$67.58
Filters	\$8,500,000	\$46.20	\$143.22
UV Disinfection System	\$3,500,000	\$19.00	\$58.90
Discharge Culvert	\$450,000	\$2.40	\$7.44
Total	\$68,480,000	\$373	\$1,155
Annual O&M Cost			
Labor and Materials	\$400,000/yr	\$2.20	\$6.82
Energy for UV Irradiation	\$40,000/yr	\$0.20	\$0.62
Energy for Pumping	\$90,000/yr	\$0.50	\$1.55
Total	\$530,000/yr	\$2.90/yr	\$8.99/yr

Table 13			
Summary of Opinion of Probable Costs for Capital and O&M for Conventional Detention and UV Disinfection System at the Chino Creek Study Site			
Chino Creek - 0.5 inch Rainfall (300 cfs, 24 hr average flow)			
Capital Cost	Total	Per Capita	Per Household
Inflatable Dam	\$530,000	\$1.80	\$5.58
Diversion Culvert	\$2,700,000	\$9.10	\$28.21
Underground Detention Storage	\$130,000,000	\$438.40	\$1,359.04
Pump Station	\$6,000,000	\$20.20	\$62.62
Filters	\$25,000,000	\$84.30	\$261.33
UV Disinfection System	\$4,900,000	\$16.50	\$51.15
Discharge Culvert	\$570,000	\$1.90	\$5.89
Total	\$169,700,000	\$572	\$1,774
Annual O&M Cost			
Labor and Materials	\$800,000/yr	\$2.70	\$8.37
Energy for UV Irradiation	\$40,000/yr	\$0.10	\$0.31
Energy for Pumping	\$85,000/yr	\$0.30	\$0.93
Total	\$925,000/yr	\$3.10/yr	\$9.61/yr
Chino Creek - 10 ft²/sec Runoff Condition (100 cfs, 24 hr average)			
Capital Cost	Total	Per Capita	Per Household
Inflatable Dam	\$530,000	\$1.80	\$5.58
Diversion Culvert	\$1,500,000	\$5.10	\$15.81
Underground Detention Storage	\$65,000,000	\$219.20	\$679.52
Pump Station	\$2,500,000	\$8.40	\$26.04
Filters	\$5,500,000	\$18.50	\$57.35
UV Disinfection System	\$3,000,000	\$10.10	\$31.31
Discharge Culvert	\$350,000	\$1.20	\$3.72
Total	\$78,380,000	\$264	\$819
Annual O&M Cost			
Labor and Materials	\$250,000/yr	\$0.80	\$2.48
Energy for UV Irradiation	\$20,000/yr	\$0.10	\$0.31
Energy for Pumping	\$45,000/yr	\$0.20	\$0.62
Total	\$315,000/yr	\$1.10/yr	\$3.41/yr
Chino Creek - 0.1 inch Rainfall (60 cfs, 24 hr average flow)			
Capital Cost	Total	Per Capita	Per Household
Inflatable Dam	\$530,000	\$1.80	\$5.58
Diversion Culvert	\$1,500,000	\$5.10	\$15.81
Underground Detention Storage	\$45,000,000	\$151.70	\$470.27
Pump Station	\$2,000,000	\$6.70	\$20.77
Filters	\$3,500,000	\$11.80	\$36.58
UV Disinfection System	\$1,500,000	\$5.10	\$15.81
Discharge Culvert	\$300,000	\$1.00	\$3.10
Total	\$54,330,000	\$183	\$568
Annual O&M Cost			
Labor and Materials	\$165,000/yr	\$0.60	\$1.86
Energy for UV Irradiation	\$10,000/yr	\$0.00	\$0.00
Energy for Pumping	\$25,000/yr	\$0.10	\$0.31
Total	\$200,000/yr	\$0.70/yr	\$2.17/yr

Table 14				
Summary of Opinion of Probable Costs for Capital and O&M for an Infiltration Basin at the Chino Creek Study Site				
Chino Creek - 0.1 inch Rainfall (60 cfs, 24hr average flow)				
Capital Cost		Total	Per Capita	Per Household
Inflatable Dam		\$550,000	\$1.90	\$5.89
Diversion Culvert		\$1,500,000	\$5.10	\$15.81
Pump Station		\$2,000,000	\$6.70	\$20.77
Infiltration Basin		\$8,500,000	\$28.70	\$88.97
	Total	\$12,550,000	\$42	\$131
Annual O&M Cost				\$0.00
Labor and Materials		\$260,000/yr	\$0.90	\$2.79
Energy for Pumping		\$15,000/yr	\$0.10	\$0.31
	Total	\$275,000/yr	\$1.00/yr	\$2.79/yr

Subsurface Flow Wetland

As noted earlier, given available land limitations, a subsurface flow wetland is potentially feasible only for the runoff from the 0.1 inch rainfall event for the Chino Creek study subwatershed. Costs for the subsurface flow wetland include capital costs, including the cost for a detention tank construction of a pump station and diversion structures, and the wetlands system; and O&M costs including wetland upkeep, energy usage, and diversion structure maintenance.

Capital costs for a pump station and influent conveyance channels were based on design and unit cost assumptions including a total head loss 20 ft, 75% pump efficiency, and station cost of \$1,500 per pump horse power, and 500 ft distance from an inflatable dam turnout to the subsurface flow wetland. Capital costs for the wetland were updated from a per acre cost of \$138,000 estimated by the USEPA in a technological assessment (US EPA, 1993). Table 15 summarizes the capital and O&M costs for a subsurface flow wetland at the Chino Creek study site for the 0.1 inch rainfall event.

Table 15				
Summary of Opinion of Probable Costs for Capital and O&M for a Constructed Subsurface Flow Wetland at the Chino Creek Study Site				
Chino Creek - 0.1 inch Rainfall (60 cfs, 24hr average flow)				
Capital Cost		Total	Per Capita	Per Household
Inflatable Dam		\$550,000	\$1.90	\$5.89
Diversion Culvert		\$1,200,000	\$4.00	\$12.40
Underground Detention Storage		\$45,000,000	\$151.70	\$470.27
Pump Station		\$2,000,000	\$6.70	\$20.77
Subsurface Flow Wetland		\$17,000,000	\$57.30	\$177.63
Discharge Culvert		\$300,000	\$1.00	\$3.10
	Total	\$66,050,000	\$223	\$690
Annual O&M Cost				
Labor and Materials		\$/yr 420,000/yr	\$1.40	\$4.34
Energy for Pumping		\$/yr 25,000/yr	\$0.10	\$0.31
	Total	\$445,000/yr	\$1.50/yr	\$4.65/yr

Dry-Weather Diversion to Existing WWTP

Dry-weather diversion to an existing WWTP is considered feasible for up to 4 cfs of flow from the Santa Ana Delhi Channel subwatershed. Costs for this option would include the capital costs of buying capacity at the Orange County Sanitation District (OCSD) Plant No. 2 WWTP and construction of diversion structures and piping. O&M costs include pumping energy costs and annual WWTP charges. The cost of energy anticipated to be used by the pump station was based on an assumed rate of 15 cents per kWh. Pipeline probable costs of construction were based on an assumption of \$240/ft of pipe for a 12 inch pipe (based on a unit cost of \$18/diameter inch/ft of pipeline). Pump station costs were developed as a function of design capacity. A total head loss of 100 ft was used to estimate the pump station capacity. Other assumptions for the pump station capital's probable cost of construction include a pump efficiency of 75% and capital cost of \$1,500 per horse power. Table 16 summarizes the capital and O&M costs for dry weather diversion of 4 cfs to the OCSD HB WWTP from the Santa Ana Delhi Channel study site.

Santa Ana Delhi Channel - Dry Weather Runoff (4 cfs, 24hr average flow)			
Capital Cost	Total	Per Capita	Per Household
Inflatable Dam	\$550,000	\$2.70	\$8.37
Pump Station	\$100,000	\$0.50	\$1.55
Pipeline Construction - 4.5 miles	\$5,700,000	\$28.00	\$86.80
Plant Capacity – 4 cfs	\$1,600,000	\$7.80	\$24.18
Total	\$7,950,000	\$39	\$121
Annual O&M Cost			
Treatment Cost at WWTP	\$805,000/yr	\$3.90	\$12.09
Energy for Pumping	\$30,000/yr	\$0.10	\$0.31
Total	\$835,000/yr	\$4.00/yr	\$12.71/yr

Preliminary Findings

Based on this preliminary economic analysis, the following findings are presented for consideration by the Stormwater Quality Standards Study Task Force:

- Treating stormwater flow rates resulting from larger storm events to achieve current bacteria water quality standards will result in significant costs. The cost associated with treating increasing flow rates increases significantly.
- Conventional wetland treatment systems have proven to be effective in reducing bacteria levels in some prior systems, but do not appear to be feasible in these study subwatersheds due to required sizing compared to the available land.

- Infiltration basins and subsurface wetlands may be feasible in limited locations for wet weather low flow rates and may result in considerably less cost to implement over other alternatives, but are land intensive compared to the other alternatives, which significantly restricts their applicability to large watersheds and higher flow rates.
- The dominant cost component and high peak flow hydrographs of each option analyzed is that associated with addressing the, short term duration of storm flows. Implementing flow storage and equalization measures (detention storage) to allow for effective treatment is by far the largest component of control measure capital cost.

References

- Bays, James and Nancy Palmer. "Treatment Wetlands Remove Fecal Coliform Bacteria from Low-Flow Urban Runoff in Southern California." Western Chapter, Society of Wetland Scientists, "Headwaters to Oceans" Conference. October 23, 2003.
- CASQA, 2003. California Stormwater BMP Handbook, New Development and Redevelopment.
- City of Encinitas, 2006. *Moonlight Beach Urban Runoff Treatment Facility*. Final Report to the State Water Resources Control Board. [Online]
http://www.ci.encinitas.ca.us/NR/rdonlyres/5612D387-D6D9-48A7-AF7F-A9D039C78547/0/Moonlight_Beach_Urban_Runoff_030806.pdf
- City of Los Angeles Bureau of Engineering, Department of Public Works. "Ballona Creek Treatment Facility Feasibility Study and Preliminary Design." May 1996.
- Davis, Luise. "A Handbook of Constructed Wetlands; a guide to creating wetlands for: Agricultural Wastewater, Domestic Wastewater, Coal Mine Drainage, Stormwater in the Mid-Atlantic Region; Volume 5 Stormwater." USDA-Natural Resources Conservation Service and the US EPA-Region III.
- Lyon, Stephen, 2006. "Subsurface-Flow Constructed Wetlands for Water Treatment." *Southwest Hydrology*, Vol. 5, No. 1, pp. 26-28.
- Meregillano, Tom B. Orange County Sanitation District, Source Control Division, Regulatory Specialist. Personal Communication, 4/12/06, 714-593-7457.
- Metcalf & Eddy, Inc., 2003. *Wastewater Engineering: Treatment and Reuse*. 4th Edition. New York, NY. McGraw-Hill Inc.

Orange County Stormwater Program. "Appendix E1 BMP Effectiveness and Applicability for Orange County." June 2005. Prepared by RBF Consulting. [Online]
http://www.ocwatersheds.com/stormwater/PDFs/2003_Appendix_E/2003_Appendix_E1_BMP_Effectiveness.pdf

Palisade Corporation. "Guide to Using @Risk. Risk Analysis and Simulation Add-In for Microsoft Excel. Version 4.5.", Palisade Corporation, 2005, Ithaca, NY.

Schueler, Thomas R. (Dept. of Environmental Programs, MWCOG). "Design of Stormwater Wetland Systems: guidelines for creating diverse and effective stormwater wetlands in the mid-Atlantic Region." October 1992.

Susilo, K., Kenmerle, B., Dekermenjian H., and D. Jones. "Santa Monica Bay Beaches Wet Weather Bacteria TMDL Implementation Plan - Technical Memorandum Task 6: Treatment and Management Options." 2004.

University of Southern California, Southern California Studies Center and the Brookings Center on Urban and Metropolitan Policy. *Sprawl Hits the Wall; Confronting the Realities of Metropolitan Los Angeles*, 2001.

US Environmental Protection Agency. *Subsurface Flow Constructed Wetlands for Wastewater Treatment; A Technology Assessment*, EPA832-R-93-008, July 1993.

USDA Soils Conservation Service Engineering Division. *Technical Release 55 Storage Volumes for Detention Basins*, Chapter 6. June 1986.

Woodward Clyde, 1998. *Final Long-Term Solution Feasibility Report, North Beach Water Quality Compliance Study, Coronado, California*, Final report to the City of Coronado, CA. Woodward Clyde Consultants, Oakland, CA.

Zimmerman, Bruce. The Coombs-Hopkins Company, UV Radiation Systems. Personal Communication, April 2006, 760-931-0555.

Attachment A
General Descriptions, Components,
and Design Criteria for Structural BMP Options

Constructed Free Surface Flow Wetlands

A constructed free surface flow (FSF) wetland treatment system was considered for controlling bacteria at target flow conditions at the outlet of each study subwatershed. The primary removal mechanisms for bacteria in a wetland system include:

- Natural die-off
- Sedimentation, sorption, and infiltration
- Ultraviolet light
- Temperature effects
- Exposure to antibiotics released by the roots of wetland plants
- Predation from other microbes and animals

In some cases, increases in bacteria concentration have been reported in a wetland treatment system, due to wildlife that is attracted to wetland habitat. Measures can be taken to prevent many animals from entering a FSF wetland, such as constructing fences, however a sufficient means does not exist to prevent birds from entering the wetland. As long as waste is not introduced at the outlet, pathogens can be at least partially eliminated through the removal mechanisms above. However waste introduced at the outlet of the wetland is likely to contribute to pollution in the receiving water.

Expected effluent concentrations from a constructed wetland would provide the most useful value to this compliance alternatives analysis. However, this measure of BMP effectiveness for constructed wetlands is difficult to ascertain given a wide range of observed influent and effluent concentrations from a small number of case studies in Southern California. Alternatively, removal efficiency is another measure that can be used to express BMP effectiveness. Most of the studies reviewed as part of this compliance alternatives analysis presented BMP performance results in the form of a removal efficiency. Removal efficiencies can be considered in terms of percent removal or log removal and can be incorporated into a water quality model by using a flat removal efficiency or time-dependent decay rate. Several studies have reported 2-log removal of influent bacteria concentration; however this efficiency is not always consistent for a given wetland and does not provide a conservative estimate based on the variability observed at wetlands across the country. The Orange County Stormwater Program conducted a study of existing wetlands data, including nine projects across North America for wet pond percent removal efficiency. Removal efficiencies ranged from -6% to 99% (2-log removal). A mean removal rate was determined to be 70% removal. Based on this study, a flat removal efficiency of 70% will be used for this analysis, with the assumption of a minimum 7 day residence time.

Constructed wetlands should be designed with a sediment forebay that has the capacity to store at least 10% of the treatment volume at a depth of 4 to 6 feet. The outlet

structure of the wetland area should also include a micropool that has the capacity to store at least 10% of the runoff volume in order to prevent clogging the outflow drain. Trash racks or hoods on the outflow riser will also help to prevent clogging. In addition, the outlet drain can be reverse-sloped to prevent clogging.

Plants must be chosen that can accommodate the frequency and depth of water. A dry-weather flow channel will be permanently wet, however the water level should not regularly exceed ½ ft. These conditions can support several plant species, including softstem bulrush, common three-square, pickerelweed, sedges, rushes, and arrow arum (Davis, 2000). The stormwater treatment area must contain plants that can withstand flooding during wet-weather events, but also thrive during drier periods. Recommended plants include trees such as black willow and river birch, shrubs such as buttonbush and chokecherry, as well as softstem bulrush, sedges, switchgrass, and rice cutgrass. When possible, native plants should be used in order to prevent invasive species from thriving. A conceptual flow diagram for a FSF wetland treatment system is found in Figure 1.

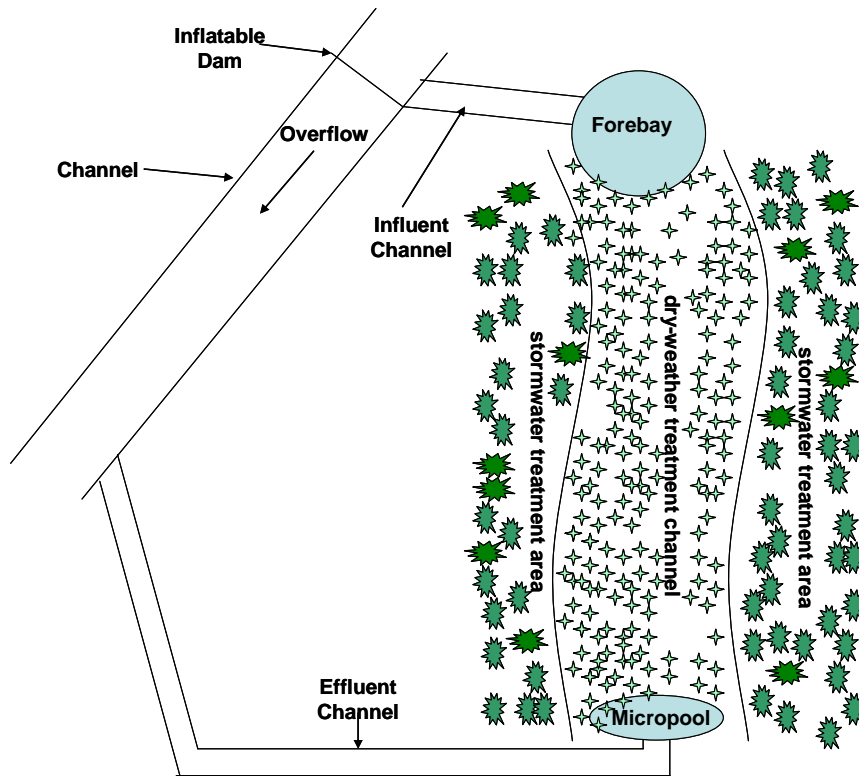

Figure 1
Conceptual Flow Diagram for a Constructed Wetland

Subsurface Flow Wetlands

In subsurface flow (SSF) wetlands, water flows through the sub-surface soil matrix, rarely surfacing. Wetland plant species are planted within the soil matrix and remove pollutants by uptake. The presence of aerated and anoxic zones is also thought to enhance removal. Due to enhanced filtration processes, an anaerobic environment,

reduced residence time, and a lack of inhabiting animals contributing to bacteria loads, SSF wetlands are considered to be more effective for bacteria removal than FSF wetlands. Therefore, where possible, SSF wetlands should be considered first. Various modifications have been made to specific designs of SSF wetlands in order to enhance treatment effectiveness. One modification is the use of a backflow pump to purge the wetlands of fine sediments and other potentially clogging materials. Another is the addition of nutrients to SSF wetlands to promote vegetative and beneficial bacterial growth. This is generally required when an inert substrate such as sand is used. Removal of suspended solids upstream of the wetland will enhance performance and increase the lifespan of SSF wetlands.

Subsurface wetlands should be constructed in parallel media beds. The media should be at least 3/8" gravel to prevent mechanical and biological clogging. Minimum porosity and conductivity of the coarse grained materials should be on the order of 0.3-0.35 and 1-100 cm/s, respectively. A layer of fine organic substrate is required on the ground surface for establishment of the vegetative cover. The dimensions of each media bed should be on the order of 10 feet wide, 20 feet long, and about 4-5 feet deep. Wider cells are possible, but the length of the flow path should generally be limited to about 20-40 feet (depending on media type) to minimize head drop across the bed. The media bed would be constructed by simple excavation, with a slope of about 1/2 to 1 percent from inlet to outlet. The media bed should be lined to prevent infiltration and interaction with the groundwater. Common liner materials are 30-mil PVC or HDP pond liners. Other options include compacted clay or concrete. Note that subsurface wetlands can be constructed above ground as well.

The inlet and outlet works can be distribution trenches that are filled with high permeability materials (or open structures) to help distribute flows uniformly across the media bed. There is flexibility in the type of media that may be used in the distribution trenches, including large gravel and stones, wire mesh gabions filled with stones, pipe networks, or synthetic, high porous, high strength plastic modular infiltration blocks. Influent can simply be distributed over the surface of the inlet trench, or alternatively could be distributed in a buried perforated pipe manifold. The outlet pipe can be a slotted collection pipe that is buried in the outlet trench, and is connected to a level control device to control water levels in the media bed or a collector trench.

Subsurface flow wetlands should have a minimum detention time of 1-day, which has been shown to provide excellent removal of indicator bacteria. In practice the actual average detention time will be less than the theoretical detention time due to deviations from uniform flow conditions. An actual detention time of approximately 75 percent of the theoretical maximum has been suggested. Based on the media bed dimensions and the detention time above, the treatment capacity for each media bed is estimated at 210 cf/d. On a per acre basis, this is roughly equivalent to 0.5 cfs/acre or 0.33 MGD/acre. This area estimate only includes the media bed area, which will be the vast majority of the area requirement. A conceptual flow diagram for a SSF wetland treatment system is found in Figure 2.

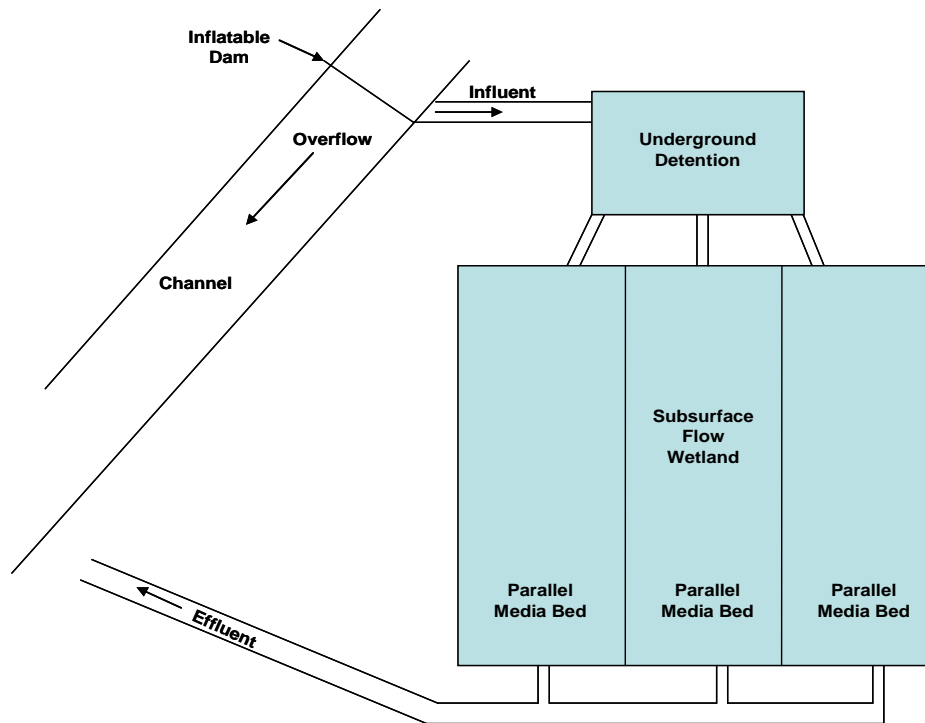

Figure 2
Conceptual Flow Diagram for a Subsurface Flow Constructed Wetland

Conventional Disinfection Facility

A conventional disinfection facility was considered for bacteria at target flow conditions at the outlet of each study subwatershed. This structural BMP would consist of a diversion of flow to a detention structure, from which water is pumped through a treatment train including pre-filtration and UV irradiation for disinfection.

To produce UV radiation, low-pressure mercury vapor lamps are charged, and the energy generated by the excitation of the vapor results in the emission of UV light. Radiation penetrates the cell wall of the microorganism and is absorbed by the nucleic acid or DNA, to either prevent replication or cause death of the cell.

A UV irradiation facility generally consists of a power supply, ballast or capacitors, high-intensity lamps, reaction chamber, cleaning apparatus, and controls and instrumentation. Stormwater applications of UV disinfection are rare, but are beginning to become more popular. For example, the City of Encinitas, CA recently installed a UV disinfection system to treat stormwater discharges to Moonlight Beach (City of Encinitas, 2006). In a similar application, the City of Coronado, CA installed a UV disinfection system for treating both groundwater and stormwater (combined system) prior to discharging to the ocean (Woodward Clyde, 1998).

The effectiveness of UV disinfection depends primarily on the uniformity of flow velocities and the clarity of the influent water. Solid particles can greatly affect the performance of a UV system by minimizing light penetration and shielding bacteria.

Furthermore, the characteristics of the target organisms and the chemical characteristics of the influent may have an affect on UV bacteria removal effectiveness. Hydraulic controls and conveyances designed to achieve a nearly uniform velocity field through the reaction chamber can enhance performance. The UV lamp encasements must be routinely cleaned so that the UV light is not hindered by algal growth and calcium deposits (Metcalf & Eddy, 2003). The screening of small rocks, gravel, or litter is necessary to avoid the blockage of UV light or damage to the quartz sleeve which encases the lamp. Figure 3 depicts a conceptual flow diagram for the treatment of wet weather design flows using the conventional system of UV disinfection.

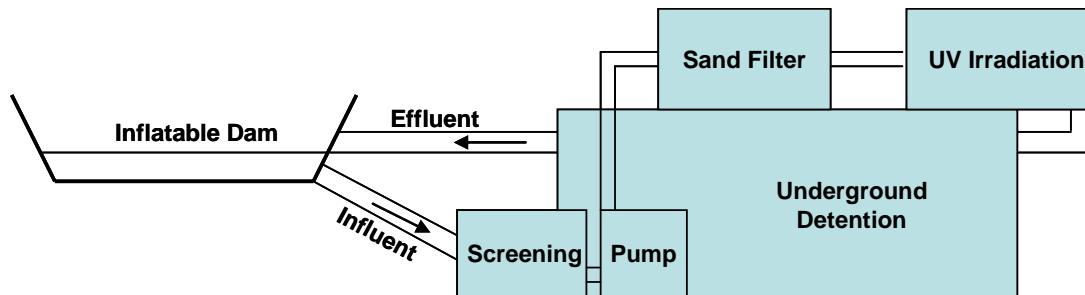

Figure 3
Conceptual Flow Diagram for Conventional Disinfection Treatment

Additional storage would be necessary to capture the volume of runoff during the part of a storm event that occurs above the capacity of the disinfection system, which could be sized to treat one half of the mean event flow for a maximum 48 hour drawdown. Soil Conservation Service (SCS), which is now the National Resources Conservation Service (NRCS), developed Technical Release 55 (TR-55) to provide guidelines for estimating runoff and designing storage BMPs in urban watersheds. TR-55 provides a method for calculating the storage necessary to capture a runoff hydrograph given a peak flowrate and treatment outflow (SCS, 1986).

In order to capture flows, a subsurface detention basin would be utilized, which would likely consist of a pre-cast concrete tank. Concrete has high strength and durability, and does not require labor intensive maintenance that is typically required for steel tanks, such as sandblasting and exterior coating. Utilizing pre-cast tanks is considered a cost-effective, virtually maintenance-free alternative. An underground detention tank would receive flow from an inlet channel and store up to the maximum wet-weather design flow, with the storage rate set at two times greater than the treatment rate. Pumps could convey flow to a pre-cast concrete filtration system before reaching the UV disinfection channels.

Infiltration Basin

Infiltration facilities generally consist of a large shallow basin, capable of retaining the entire volume of a design storm and infiltrating this volume over a specified period. A

48 hour drawdown is recommended to minimize vector and odor issues that can be associated with standing stormwater, and to be prepared to capture a subsequent storm event.

The primary mechanism for bacteria removal in regional infiltration basins is volume reduction to receiving waters and, for storms smaller than the design storm, complete removal of bacteria by preventing any surface discharge. Infiltration facilities achieve high levels of treatment of bacteria and other pollutants by impounding water and allowing it to slowly percolate into the ground. It should be noted that the permanent removal of flow from a channel may impair the designated beneficial use for a waterbody. Figure 4 provides a conceptual flow diagram for an infiltration basin BMP.

The infiltration rate of local soil types and the storage capacity of the groundwater basin are the dominant factors that determine whether infiltration of stormwater is feasible. Soils with a large silt or clay component have substantially lower infiltration rates than sandy soils, and therefore are generally poor candidates for infiltration. Variable soil horizons and depths to underlying bedrock at each site will impact actual infiltration characteristics for a specific location, thus infiltration testing will be necessary to determine actual infiltration response. The California Stormwater Quality Association Municipal BMP Handbook (Handbook) Infiltration Basin (TC-11) suggests that infiltration basins be designed with the invert at least three meters above the groundwater table, which also may render some sites unsuitable for this treatment option. TC-11 of the Handbook also recommends that basin area should be based on a design infiltration rate no greater than 50% of the lowest field measured hydraulic conductivity.

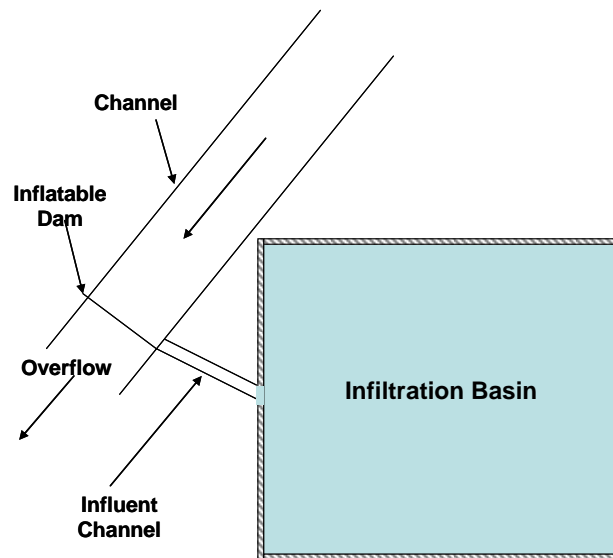

Figure 4
Conceptual Flow Diagram for an Infiltration Basin

Dry-Weather Diversion to Existing WWTP

Dry weather urban runoff diversions to WWTPs are a practical way of treating runoff, when sufficient capacity to handle additional flows is available at an existing plant and when the treatment plant is in the vicinity of the water body. The treatment option would only be utilized under dry-weather conditions, with flow remaining in the channel and by-passing the diversion under wet-weather conditions. Permanently diverting flow from the channel may impair the designated beneficial use of the waterbody. Figure 5 depicts a conceptual flow diagram for diversion of dry weather runoff to an existing waste water treatment facility.

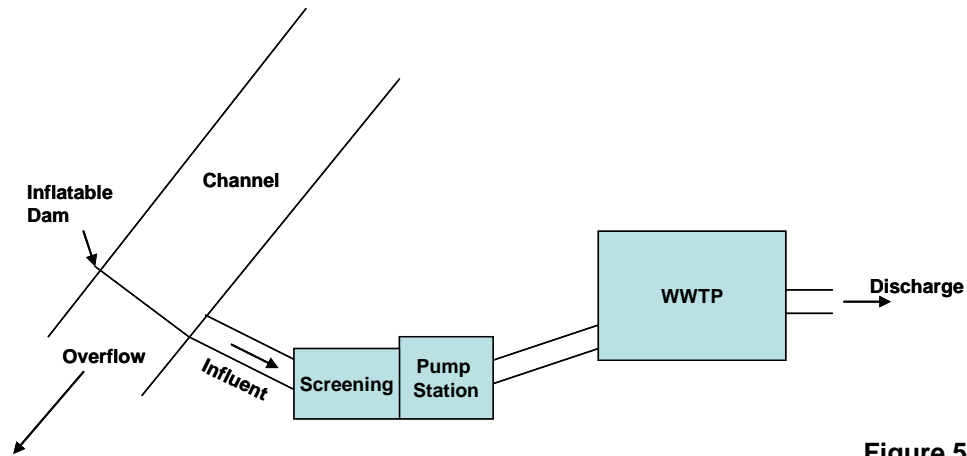

Figure 5
Conceptual Flow Diagram for Diversion of Dry-Weather Flow to an Existing WWTP